

TOSHIBA 中壓系統 保護電驛

普士電業 行銷管理部

賴邦輝 (BOND LAI)

2020/11/04

11/4/2020
Rev 01

GRE系列中壓系統多功能智慧型保護電驛

GRE-Series Multi-function protection and control IED for Medium Voltage system

▶ 系統應用

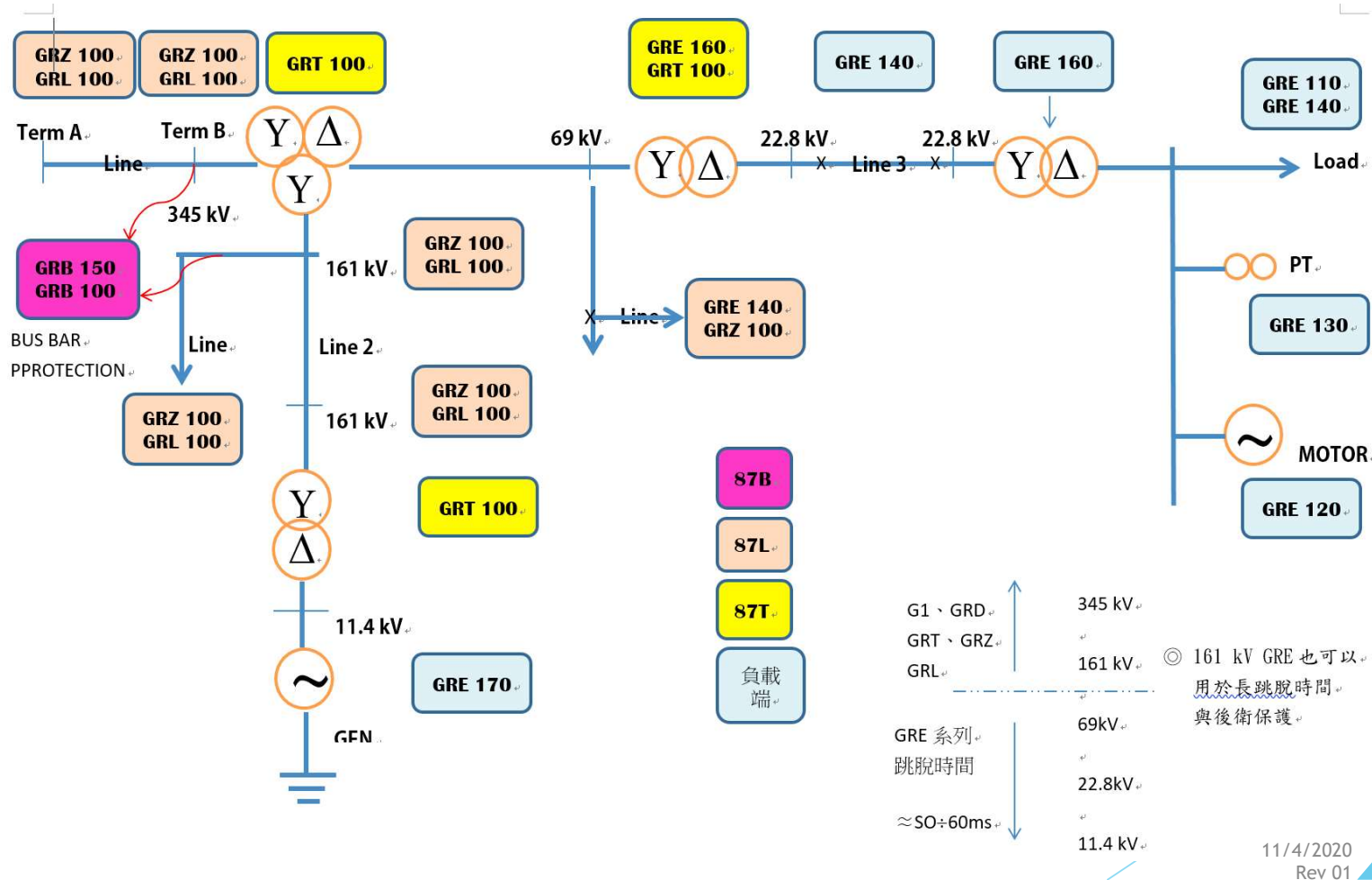

GRE系列中壓系統多功能智慧型保護電驛

GRE-Series Multi-function protection and control IED for Medium Voltage system

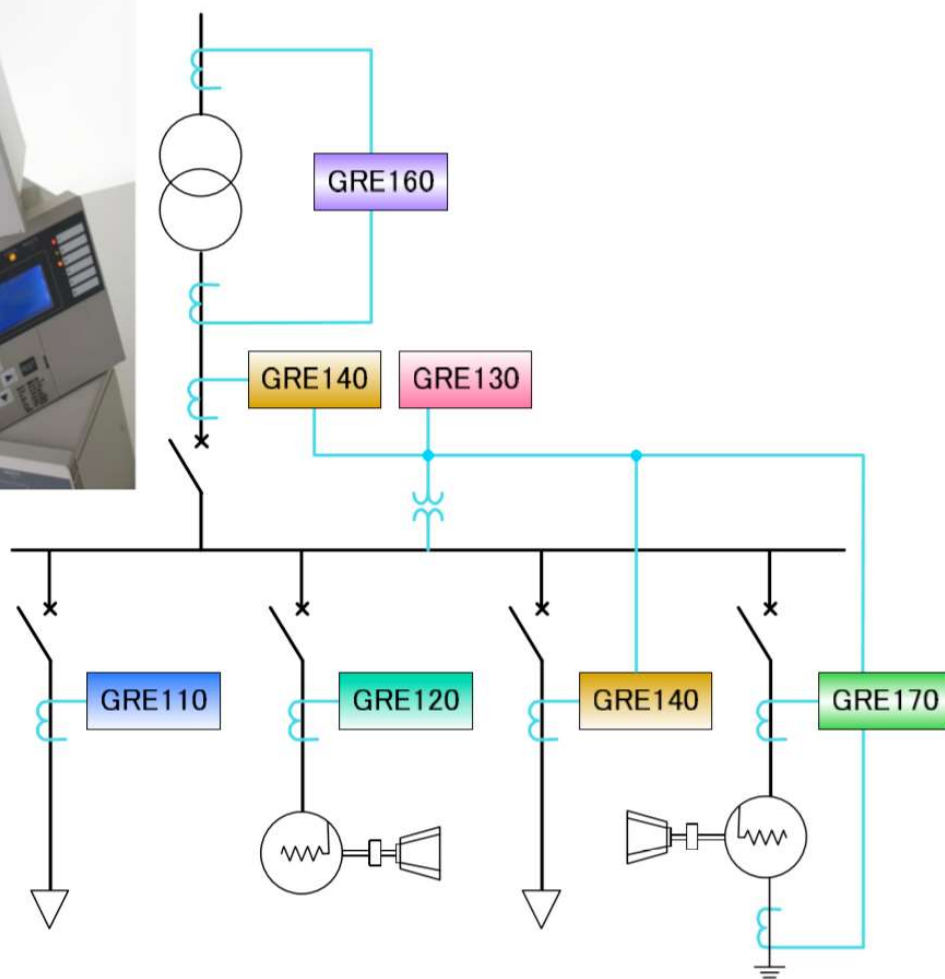

11/4/2020
Rev 01

GRE系列中壓系統多功能智慧型保護電驛

GRE-Series Multi-function protection and control IED for Medium Voltage system

► GRE系列產品應用列表

GRE 系列之應用		
應用	主要保護功能	型號
饋線保護 OV/UC	50/50N,51/51N,46,46BC, 50BF,37	GRE110
馬達保護 (Current Input)	50/50N,51/51N,49,46BC & motor protection	GRE120
電壓保護	59/59N,27,47,81OF/UF	GRE130
饋線保護 方向性 OC/EF	50/50N,51/51N,67,67N,46,46 BC,50BF,37,59,27,79,25	GRE140
變壓器保護	87T/87TN,50/50N,51/51N, 49(Thermal overload)	GRE160
機械保護	87M,50/50N,51/51N, 49(Thermal overload)	GRE170

GRE系列中壓系統多功能智慧型保護電驛

GRE-Series Multi-function protection and control IED for Medium Voltage system

► GRE 110,130



基本功能

- ◎Local/Remote 控制監視
- ◎跳脫迴路檢查(74TC)
- ◎自主檢查
- ◎CB狀態監視
- ◎告警CB操作時間警報
- ◎USB埠現場連接孔
- ◎通訊協定IEC60870-5-103,IEC61850&MODBUS通信
- ◎2組設定群組
- ◎Menu面板 HMI (16*8個介面顯示)
- ◎狀態LED (8個固定，6個可自訂)

GRE系列中壓系統多功能智慧型保護電驛

GRE-Series Multi-function protection and control IED for Medium Voltage system

▶ GRE140



基本功能

- ◎Local/Remote 控制監視
- ◎跳脫迴路檢查(74TC)
- ◎自主檢查
- ◎CB狀態監視
- ◎跳脫計數器ΣI_y
- ◎告警CB操作時間警報
- ◎USB埠現場連接孔
- ◎通訊協定IEC60870-5-103,IEC61850&MODBUS通信
- ◎其他2個設定群組
- ◎Menu面板 HMI (16*8個介面顯示)
- ◎狀態LED (8個固定，6個可自訂)

GRE系列中壓系統多功能智慧型保護電驛

GRE-Series Multi-function protection and control IED for Medium Voltage system

- ▶ GRE110 (四相一體, 3CO+1LCO)

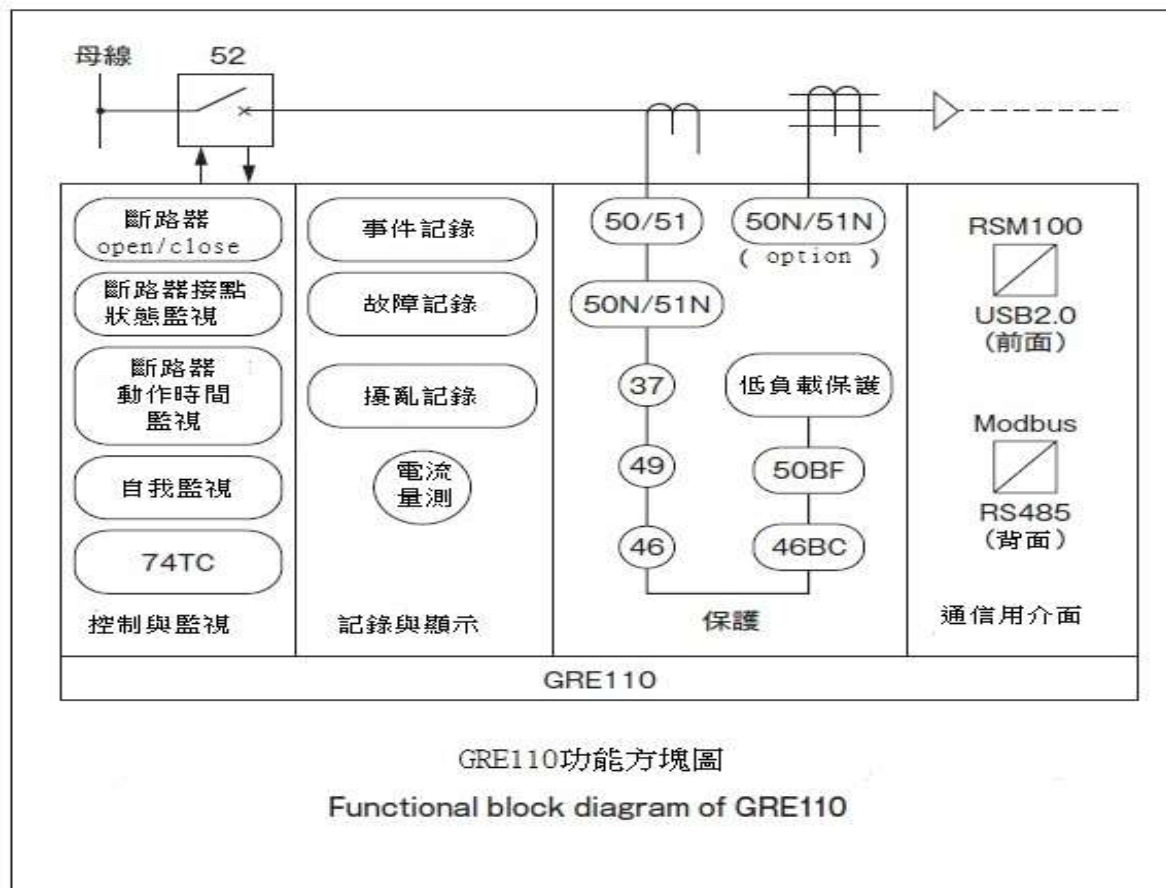

GRE系列中壓系統多功能智慧型保護電驛

GRE-Series Multi-function protection and control IED for Medium Voltage system

► GRE130 功能方塊圖 (六相一體, 3UV+30V)

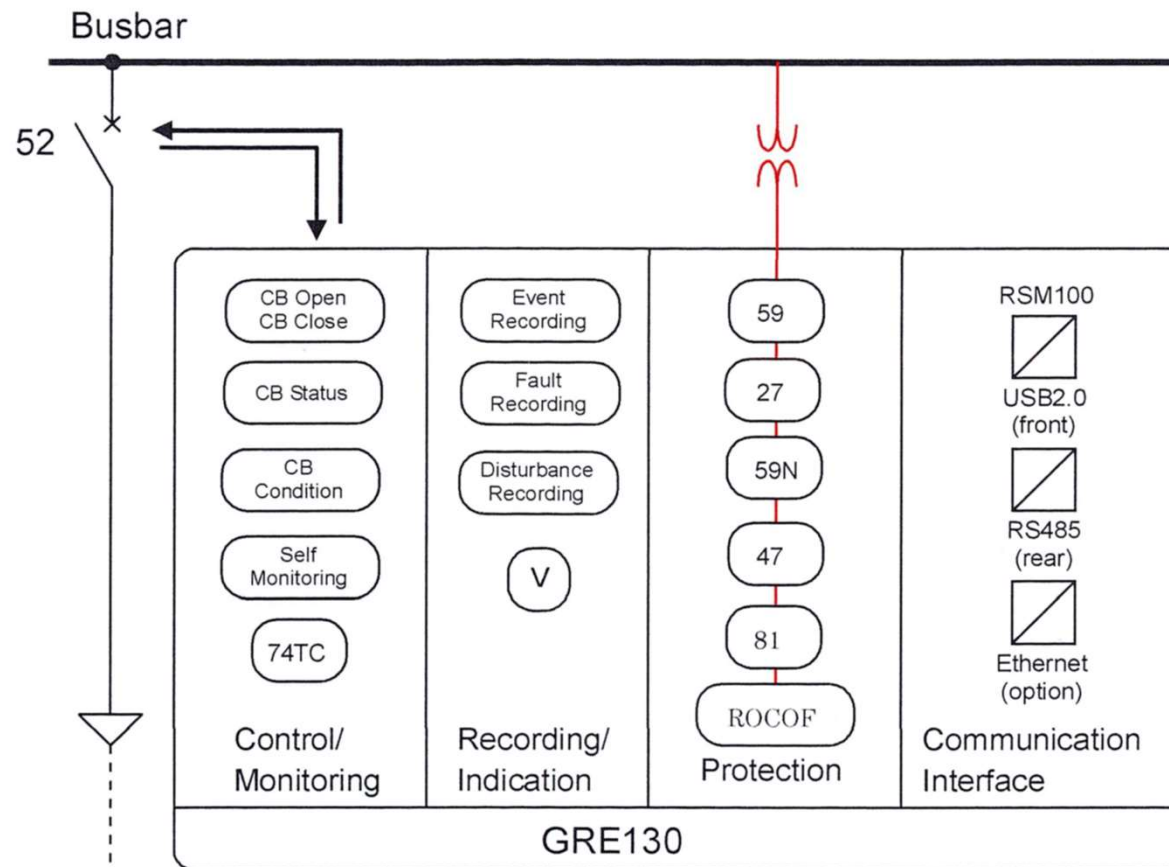

GRE系列中壓系統多功能智慧型保護電驛

GRE-Series Multi-function protection and control IED for Medium Voltage system

- GRE140功能方塊圖 (十相一體,3CO+1LOC+3UV+30V)

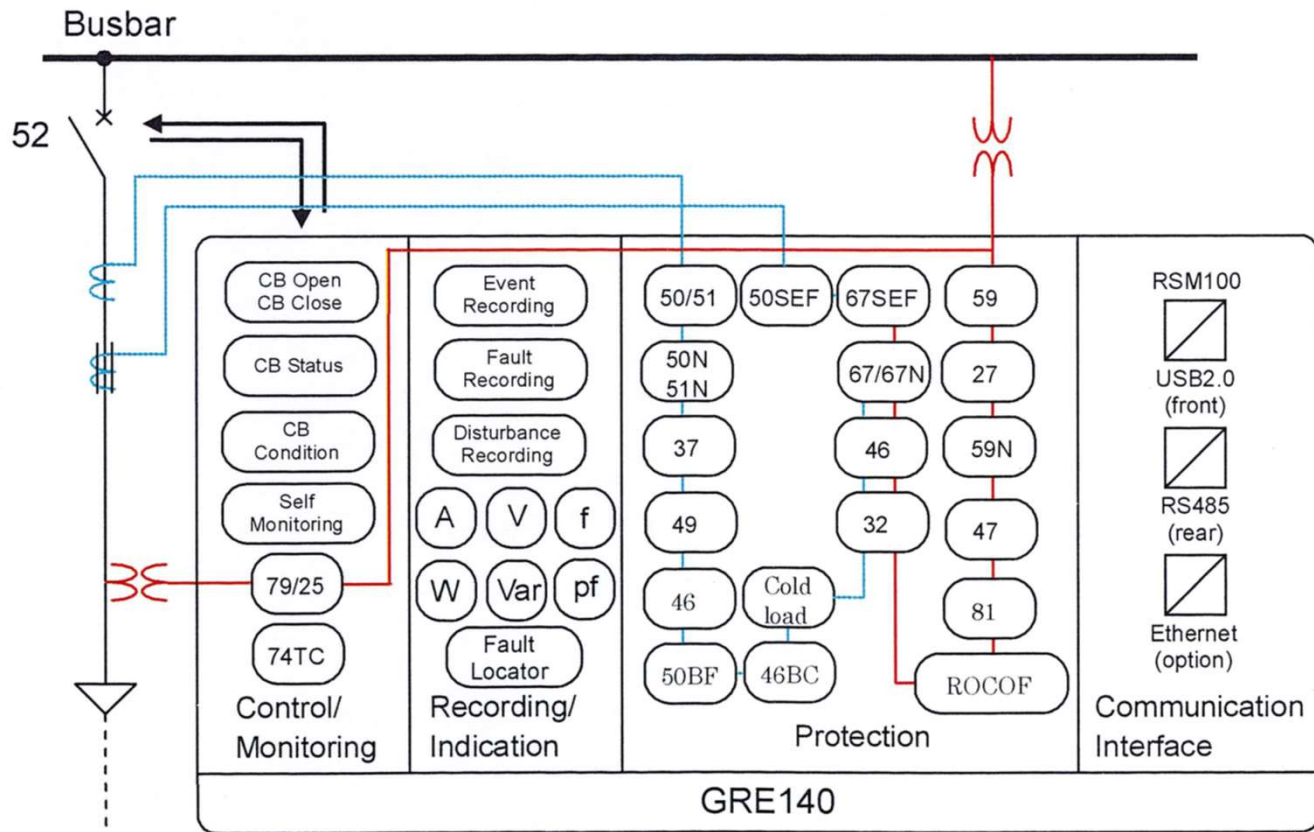

GRE系列中壓系統多功能智慧型保護電驛

GRE-Series Multi-function protection and control IED for Medium Voltage system

▶ 工程協助工具-RSM100

- Fault/event record
- Disturbance record
- Status / Settings
- Control
- Test

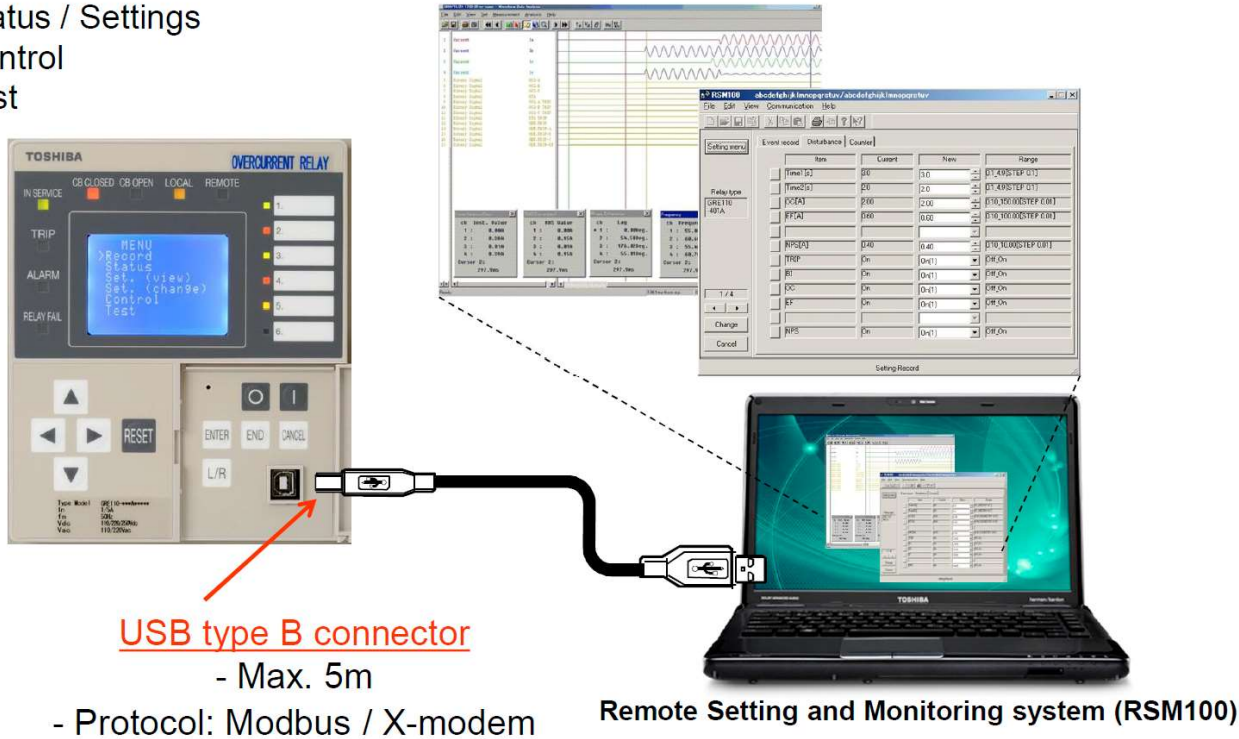

GRE系列中壓系統多功能智慧型保護電驛

GRE-Series Multi-function protection and control IED for Medium Voltage system

► SCADA/RTU 通信



RS485

RS485 twisted pair cables

- 19.2kbps for Modbus RTU
- Max. 247 units connection
- Max. 1,200m length

Protocol

With built in RS485 port

- Modbus RTU
- DNP 3.0
- IEC60870-5-103

With Optional Communication Unit

100BASE-TX / 100BASE-FX

- IEC61850
- Modbus Ether
- DNP 3.0

